



Lamborghini
CALORECLIMA



EXA 1

HIGH EFFICIENCY CAST IRON BOILER

HIGH EFFICIENCY CAST IRON BOILER

• EXA 1

• DESIGN FEATURES BOILER BODY

The boiler body, made up by cast-iron sections, has been specially developed for gas/oil operation. The design of the patented element, the optimal arrangement of fins and the calculated distance from section to section ensure adequate turbulence of combustion gases and high efficiency.

• CASING

The outer casing consists of self-interlocking steel panels, which enable a quick and easy assembly of the whole jacket. Insulation is ensured by a mineral wool lining having a high heat-insulating power.

• CONTROL PANEL

The control system comprises:

- regulating thermostat
- high limit thermostat with manual reset

• SERVICING

The furnace can be cleaned directly from the front just removing the jacket cover and the smoke chamber lid.

• OPERATIVE FEATURES INSTALLATION

Compact dimensions, absence of refractory, lining easy coupling with any type of burner are the main features that ensure a simple and quick installation in new as well as in conversion central heating systems.

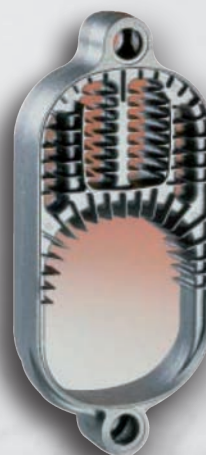

KEY

1. Adjustable thermostat
2. Safety thermostat
3. Precutting for thermometer (optional)

- a1. Flow 1" 1/2
a2. Return 1" 1/2
a3. Drain cock 1/2"

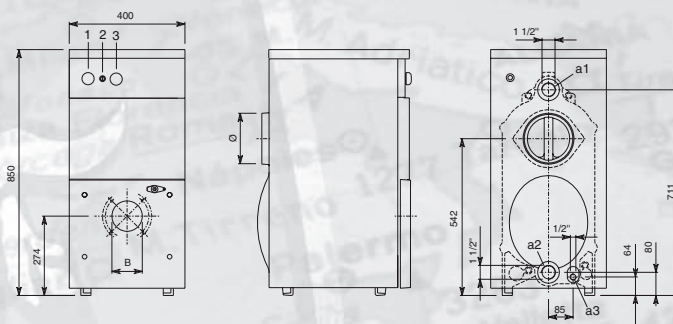

MODELS		EXA 1 02	EXA 1 03	EXA 1 04	EXA 1 05	EXA 1 06	EXA 1 07	EXA 1 08
Input	kcal/h	22.200	33.300	44.400	55.500	66.600	77.700	88.800
Heat and D.H.W. output ma	kW	23,3	34,9	46,5	58,1	69,8	81,4	93,0
Heat and D.H.W. output mi	kW	15,0	15,0	32,5	40,5	48,8	57,0	65,0
No. of elements	no.	2	3	4	5	6	7	8
Water content	l	11	14	17	20	23	26	29
Furnace lenght	mm	286	386	486	586	686	786	886
Operating pressure	bar	4	4	4	4	4	4	4
Side A	mm	300	400	500	600	700	800	900
Side B	mm	105	105	105	105	125	125	125
Boiler flue	mm	130	130	130	180	180	180	180
Pressure drop	mbar	0,11	0,12	0,13	0,15	0,17	0,18	0,20
Boiler gross weight	kg	110	140	170	200	230	260	290



Lamborghini
CALORECLIMA

Lamborghini Calor s.p.a.
Via Statale 342 - 44040 Dosso (Ferrara) - Italia
Tel. Italia 0532 / 359811 - Tel. Export 0532 / 359913
Fax Italia 0532 / 359952 - Fax Export 0532 / 359947
Internet: <http://www.lamborghinicalor.it>
E-mail: info@lamborghinicalor.it

**GRUPPO
FERROLI**